ABSTRACT

A New Model Solid State Transformer is used as a controllable bidirectional transmission device that can transfer power between asynchronous networks and functionally similar to back-to-back-HVDC. A solid-state transformer is the solution and it provides the efficient functioning as a conventional transformer and also provides other benefits, particularly on-demand reactive power maintenance for smart grid, power quality and voltage conversion. Recently, another high-frequency link power conversion system, the solid-state transformer, has garnered a great deal of attention and has been extensively investigated for use in distribution systems with the development of the high-voltage power device technologies. Solid-state transformer has been proposed as for the traction system, distribution and smart grid application. A SST uses power electronic devices and a high-frequency transformer to achieve isolation and voltage conversion from one level to another.

KEYWORDS: Solid State Transformer (SST), High Frequency (HF) Transformer, SST topology, HV/MV/LV Link.

INTRODUCTION

A typical SST consists of an AC/DC rectifier, a DC/DC converter with high-frequency transformer and a DC/AC inverter. One of the functions of a SST is similar to that of a traditional line frequency transformer (LFT), namely increasing or decreasing the voltage. In the last few years, European countries have started to open their electricity market due to this there is an increased penetration of renewable energy and other distributed generation sources in the grid. These developments cause the network layout and operation to become much more complex, new technologies are required that allow better control, bi-directional power flow and increased number of power inputs.

The SST gives way to control the routing of electricity and provides easy methods for interfacing distributed generation with the grid. The solid-state transformer also controls power flow, which is required to ensure a stable and safe operation of the grid. However, this comes at the cost of a more complex and expensive system. SST has a similar function to that of a traditional line frequency transformer (LFT), namely increasing/decreasing the voltage.

The Solid State Transformer (SST) provides an alternative to the LFT. It uses power electronics devices and a high-frequency transformer to achieve voltage conversion and isolation.

SOLID STATE TRANSFORMER CONCEPT

The basic structure of a SST is shown in Fig. 1. The HF transformer is used as an isolator. The grid voltage is converted into a HF AC voltage through the use of power-electronics converters before applied to the primary of the HF transformer. The opposite process is performed on the High Frequency transformer secondary to get an AC and/or DC voltage for the load [4].

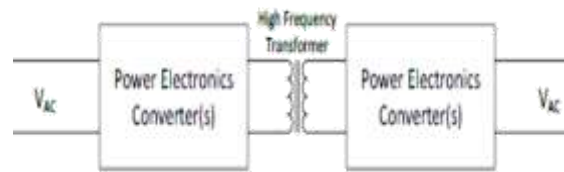

Fig. 1 Basic structure of SST

The traditional Line Frequency Transformer (LFT) has been used since the introduction of AC systems for voltage conversion and isolation. The widespread use of this device has resulted in a cheap, efficient, reliable and mature technology and any increase in performance are marginal and come at great cost [9] Additional features of the SST not found in Line frequency transformer are as below [2]:

1. Reduced size and weight.
2. Instantaneous voltage regulation.
3. Fault isolation.
4. Power factor correction.
5. Control of active and reactive power flow.
6. Fault current management on low-voltage and high voltage side.
7. Active power filtering of harmonic content on the input.
8. Good voltage regulating capabilities
9. The output can have a different frequency and number of phases than the input
10. Possibility of a DC input or output
11. Voltage dip and sag ride through capability (with enough energy storage)

SOLID STATE TRANSFORMER CONFIGURATIONS

The SST architectures developed in the last 10 years can be categorized as [10]:

- 1) SST based on their topologies:
- 2) SST based on their application:
- 3) SST architectures with focus on switching devices

Different research teams used different topologies and architectures for the Solid State Transformer.

Schematic Overview of SST based on topologies

The Solid State Transformer made up of one or more power electronics converters with an integrated high-frequency transformer. Based on the topologies, SST can be classified in four categories [11].

- 1) Single-stage with no DC link(Figure 2.a)
- 2) Two-stage with a DC link on the secondary side (Figure 2.b)
- 3) Two-stage with a DC link on the primary side (Figure 2.c)
- 4) Three-stage with a DC link on both the primary and secondary side(Figure 2.d)

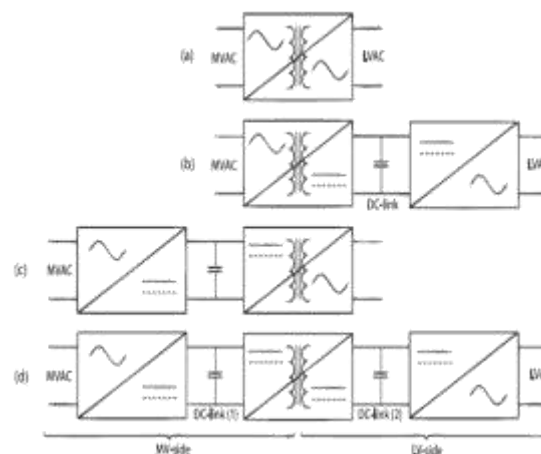

Fig. 2: SST architectures

Out of these four possible classifications, architecture from fig.2 .d, with two DCs, is the feasible because it has high flexibility and control performance. The DC links decouple the MV-from the LV-side, allowing for independent reactive power control and input voltage sag ride-through. This topology also allows better control of voltages and currents on both primary and secondary side[11][12][13].It consists of an AC-DC conversion stage at the MV-side, a DC-DC conversion stage with high-frequency transformer for isolation and a DC-AC conversion stage at the LV-side.

DESIGN AND SIMULATION

AC-DC Conversion Step

The first step in the design of solid state transformer is AC-DC conversion; in this MV/HV ac is converted in the LV Dc voltage in this stage we used three level NPC conversions topology as shown in figure below[3][8].

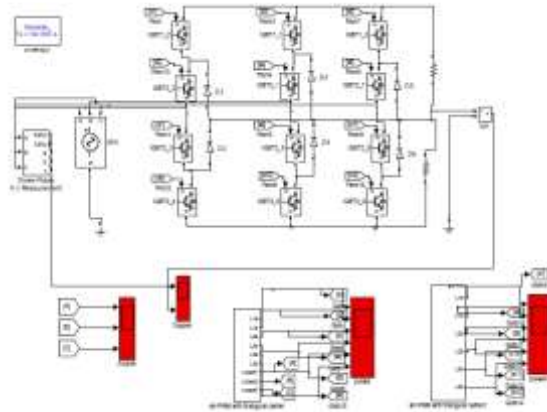

Fig. 3 AC-DC Simulation

It consist of two level VSI’s theoretically it is extended up to several levels but practically is can extend up to only five level.

Due to additional advantages, that all phases share same DC source ultimately it reduces capacitor requirement, and reactive power control can be established, it’s simple to design.[1][12][13]:

The following figure 4 shows the simulation result of three phase AC-DC conversion three level neutral point topology.

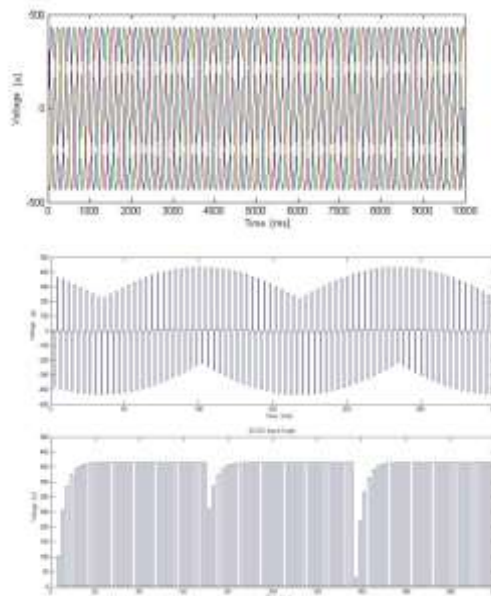

Fig. 4 Simulation result (a) AC input source (b) converted DC output

DC-DC Conversion Step

The second stage in the design of solid state transformer is DC-DC conversion stage in this stage a high frequency transformer is used for electric isolation it's mainly used for reduction of size of SST
This stage will receive input from first stage i.e. AC-DC conversion. There are several topologies which we can use for DC-DC conversion stage here in this we are using the three phase dual active bridge converter [8].

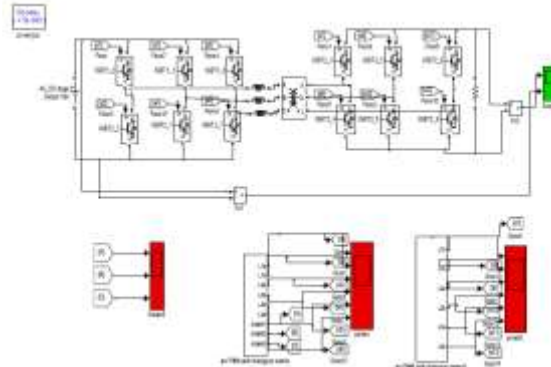

Fig. 5 DC-DC Conversion stage model

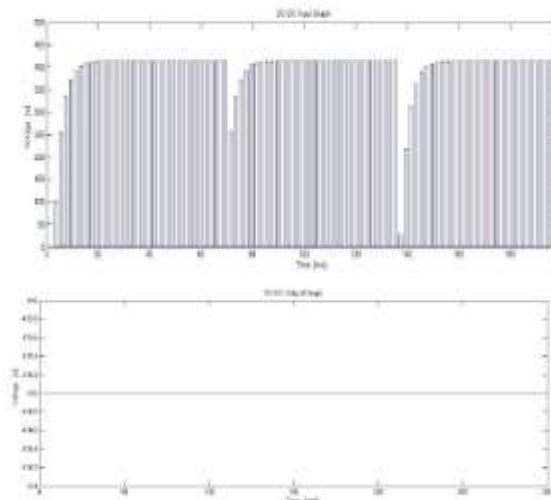

Fig.6 Simulation Result for DC-DC

here in the three phase DAB conversion model three half bridges are used in both the side of transformer due to use of one single three phase transformer it can achieve good efficiency and low rating transformer.

DC-AC Conversion Step

This is the third and final stage for SST design in this stage output from DC-DC conversion stage is converted into AC voltage. Here in the design we have used a conventional three phase to AC conversion model is used as shown in the figure 7. This is simple for designing but there are several topologies for designing this stage. The output of this stage is shown in the figure 8.

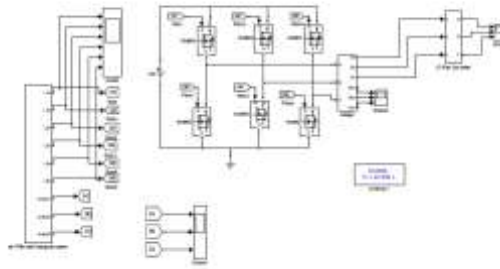

Fig. 7 DC-AC Conversion stage

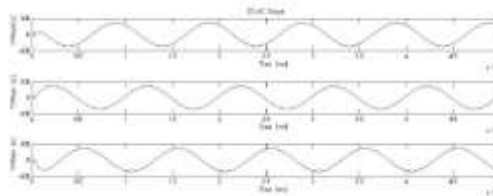

Fig. 8 Simulation Result for DC-AC

As from the three stages of SST design this will be very useful for future distribution and renewable generation system and has an advantage of compact design too. It has the ability to manage the source and load too. There are so many architectures and topologies have been investigated by researchers and everyone has its unique features therefore for grid system it is very much suitable [3][8].

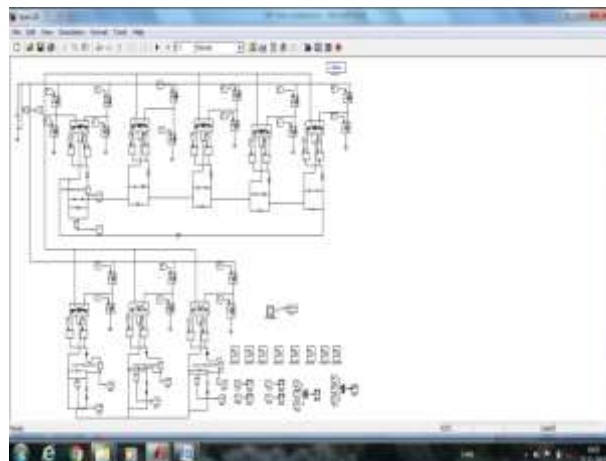

Fig.4.9 Combined module for SST [15]

The development of NMSST is shown in Fig 4.9 .Single phase ac/ac converters are applied to primary and secondary windings of a transformers the development of solid state transformer system which includes AC/AC converters with bidirectional switches connecting in full bridge arrangement. the development in Table 4.1(a) requires the least number of bidirectional switches ,but large size of transformer then the development as shown in Fig 4.9.The system consists of a high frequency single phase AC/AC converters are selected to generate high frequency voltages on transformer primary windings . on the transformer secondary side ,single phase AC/AC converter restore the voltages with input frequency .with this development the NMSST system can produce sinusoidal output voltages.[15]

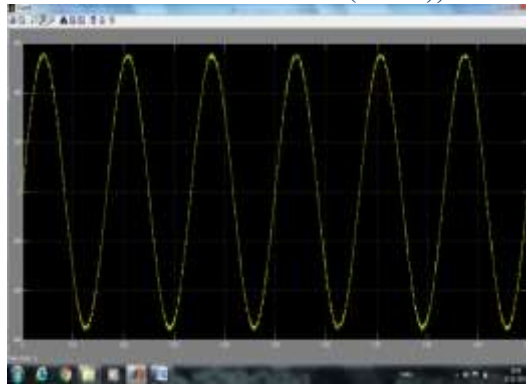

Fig.10.Primary Voltage Graph[Vpri]

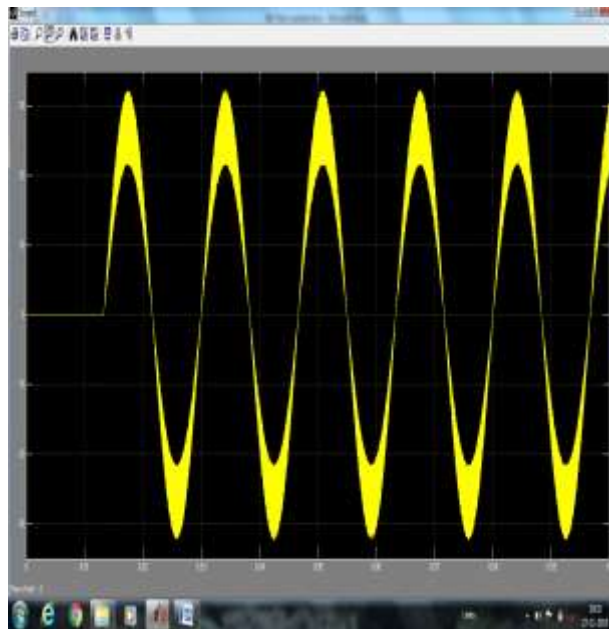

Fig.11 Primary Current of Electronic Transformer

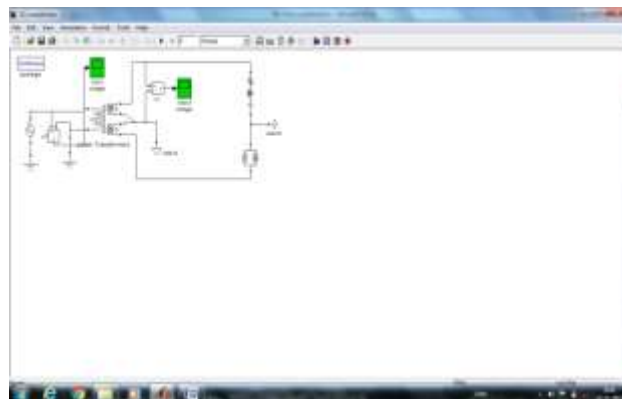

Fig.12 Transformer Module

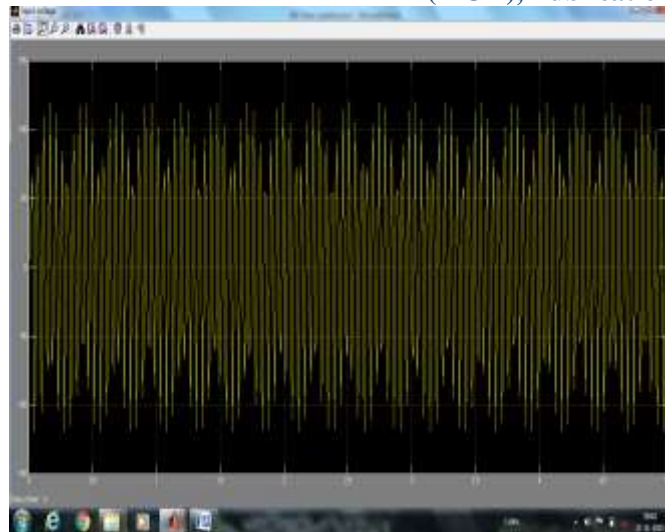

Fig.13 Transformer Primary Voltage V_{pri} at higher frequency.

APPLICATIONS OF SST

There are lots of applications where it can be used the following schematic will give a brief idea about the uses of application of SST.

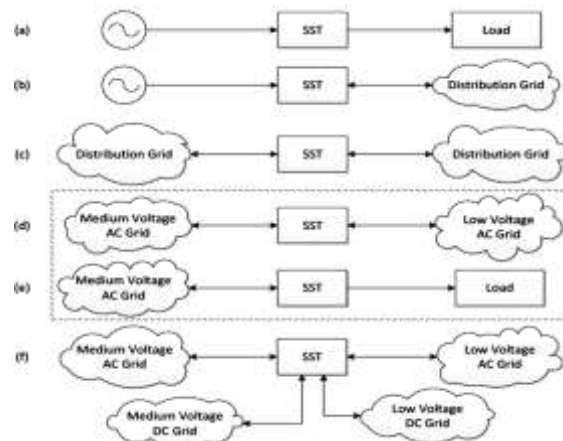

Fig. 9: Schematic overview of the SST applications Future Benefits of solid state transformer

Integration with other systems The LV DC link in the SST topology provides a good and flexible integration point for renewable energy systems in the distribution grid. When the load demand is higher than the renewable energy source capabilities then a unidirectional converter could be used. Where the highest generation capabilities exceed the load demand during certain periods, then the excess power could be fed back to the grid by using a bidirectional converter.

CONCLUSION

This paper is helpful for studying the various SST architecture and application with the help of control of current in SST it can widely used in distribution system. In this paper the concepts and developments in field of SST has been shown. Also various topologies and configuration implemented has been briefly reviewed and the model for the same is designed and the results are observed with graphs. The comparison between this various topologies of SST has been summarized. Finally it is concluded that the conventional transformer having disadvantages like bulkiness, poor voltage regulation saturation of core for non linear load, Majority of these problems can be eliminated by solid state power electronic transformer. So finally we conclude that with the help of this SST we can regulate the voltage, Source disturbance rejection, load disturbance rejection, micro grid integration and VAR compensation. Also it has the ability to work as energy router for smart grid energy

internet. Therefore application of power electronic based SST now a day's not limited up to distribution level but research work suggested that SST are having ability to replace the conventional transformer too in near future.

REFERENCES

- [1] D. C. Hopkins and M. Safiuddin, "Power Electronics in a Smart-Grid Distribution System," 2010.
- [2] M. Kezunovic, "The 21st Century Substation Design.
- [3] S.S.Bhuskute and V.S.pawar, "Design & simulation of High voltage solid state Transformer for Smart Grid Application ", Indian Research Transction, vol 05, No.2, Apr-June 2015 EISSN 2250-0804
- [4] J. L. Brooks, "Solid State Transformer Concept Development", Report of Naval Material Command, Civil Engineering Laboratory, Naval Construction Battalion Center, Port Hueneme, CA, 1980.
- [5] S. D. Sudhoff, "Solid State Transformer," US Patent No. 5, 943, 229, August 24, 1999.
- [6] E. R. Ronan, Jr., S. D. Sudhoff, S. F. Glover, D. L. Galloway, "Application of Power Electronics to the Distribution Transformer," in Proceedings of Applied Power Electronics Conference and Exposition, Feb. 2000, New Orleans, LA, pp. 861–867.
- [7] Ronan, Jr., E., Sudhoff, S., Glover, S., and D. Galloway, "A Power Electronic Based Distribution Transformer," IEEE Transactions on Power Delivery, April 2002, pp. 537–543.
- [8] Kang, M., Enjeti, P., and I. Pitel, "Analysis and Design of Electronic Transformers for Electric Power Distribution System," in IEEE Transactions on Power Electronics, Nov. 1999.
- [9] Jih-Sheng Lai, "Designing the Next Generation Distribution Transformers: New Power Electronic-Based Hybrid and Solid-State Design Approaches," in Proceedings of IASTED Power and Energy Systems, Palm Spring, CA, Feb 24-26, 2003, pp. 262–267.
- [10] J. W. van der Merwe and H. du T. Mouton, "The solid-state transformer concept: A new era in power distribution," in AFRICON 2009, 2009, pp. 1–6.
- [11] J. W. Kolar and G. I. Ortiz, "Solid State Transformer Concepts in Traction and Smart Grid Applications," Proceedings of the International Power Electronics Conference - ECCE Asia (IPEC 2014), Hiroshima, Japan, May 18-21, 2014.
- [12] S. Falcones and R. Ayyanar, "Topology comparison for Solid State Transformer implementation," in IEEE PES General Meeting, 2010, pp. 1–8.
- [13] M. R. Banaei and E. Salary, "Power quality improvement based on novel power electronic transformer," in 2011 2nd Power Electronics, Drive Systems and Technologies Conference, 2011, no. 401, pp. 286–291.
- [14] L. Heinemann and G. Mauthe, "The universal power electronics based distribution transformer, an unified approach," 2001 IEEE 32nd Annu. Power Electron. Spec. Conf. (IEEE Cat. No.01CH37230), vol. 2, pp. 504–509
- [15] Vijayakrishna Satyamsetti, Department of Power Electronics and Power Systems, School of Electrical Engineering, Jawaharlal Nehru Technological University Kakinada, Kakinada, India, "A new Model Solid State Transformer (NMSST)", International Journal of Research (IJR) Vol-1, Issue-11 December 2014 ISSN 2348-6848.
- [16] M. Claessens, D. Dujic, F. Canales, and P. Stefanutti, "Traction transformation," pp. 1–7.
- [17] A. Juneja and S. Bhattacharya, "Energy router: Architectures and functionalities toward Energy Internet," in 2011 IEEE International Conference on Smart Grid Communications (SmartGridComm), 2011, pp. 31–36.